

# HOLDER PL 9380

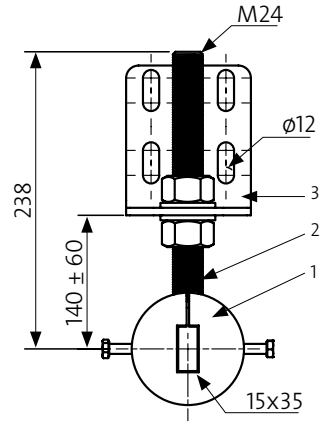

1. PU bushing 9383
2. Holder threaded part 9384
3. Angled bracket 9385

## HOLDER PL

### – Universal fixing bracket for band scraper boards.

A robust and easy to mount holder designed for Vendig's scraper boards. The holder has several adjustment possibilities, it is adjustable in height and can be angled against the conveyor belt. A square tube passes through the PU bushing for Flexus 2.

A pair of adapters 9777, is needed to fit the scraper.

All steel parts are electro-galvanized as standard. Stainless steel or powder-coated alternatives are available on request.

### FITS THESE SCRAPER BOARDS:

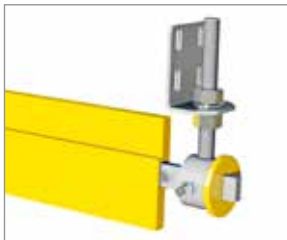

8100 PU scraper board  
+ square tube 8127.



8150 HM scraper board  
+ square tube 8127.



9750 Flexus 2. adapter 9777  
is also needed.