

# RASMUS pre-scraper 8300

---



## **RASMUS PRE-SCRAPER WITH POLYURETHANE BLADE** – Effective and simple.

The Rasmus pre-scraper 8300 really symbolises our goal to make simple, effective belt cleaners. The scraper blade attachment to the beam makes it easy to remove (without tools) when replacing the blade and when cleaning. Spare blades are available and in stock for all belt widths.

Vendig's unique spring lever ensures that the correct pressure is maintained against the belt which reduces maintenance and prolongs the lifespan of the scraper and the conveyor belt. The pre-scraper shall be positioned against the drive pulley immediately below the flow of material.

Recommended for  $\varnothing$  220-400 mm pulleys.



*Rasmus blade in detail. Full length spare part 8342 is 2.1 - 2.2m.*

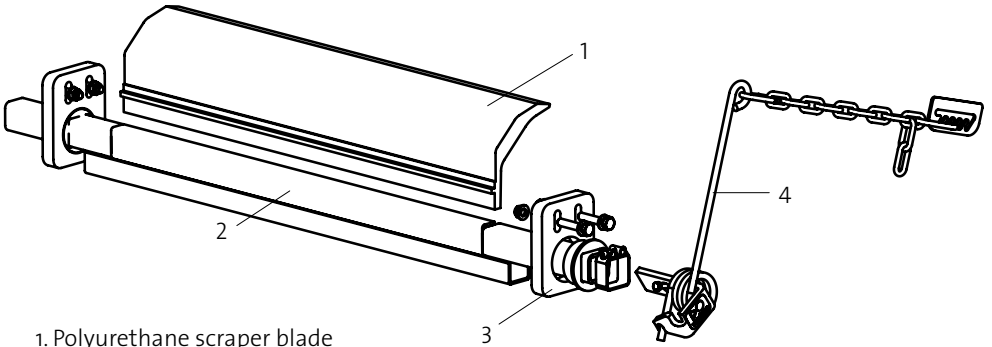

- 1. Polyurethane scraper blade
- 2. Beam
- 3. Holder H complete 8388
- 4. Lever arm complete 9178

All steel parts are electro-galvanized as standard. Stainless steel or powder-coated alternatives are available on request.

From B-W 1000 the scraper is supplied with dual lever arms.  
 From B-W 1600 the scraper is supplied with Holder HD.

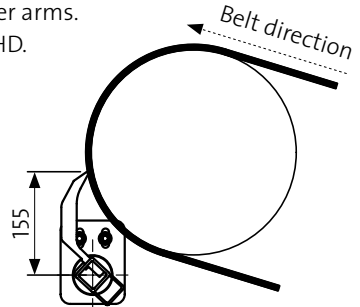

ART.NO.	B-W	SCRAPER WIDTH	BEAM LENGTH	ART.NO. SPARE BLADE
8304	400	350	1150	8324
8305	500	450	1250	8325
8306	650	550	1350	8326
8308	800	700	1500	8328
8310	1000	900	1700	8330
8312	1200	1050	1850	8332
8314	1400	1250	2050	8334
8316	1600	1450	2250	8336
8318	1800	1650	2450	8338
8320	2000	1850	2650	8340

Wider belt cleaners can be offered on request. The 8342 Rasmus blade full length is 2.1 - 2.2 m.