

1. Scraper board 8100, cut
2. Set screws
3. Flat iron
4. HolderPL1, 1 pair 9380

Picture 1

## FITTING INSTRUCTIONS

### DIAGONAL RETURN SCRAPER 8400

Tools: Socket set

Diagonal return scraper is a sturdy and easy plough. The plough is developed for reversible operations and it collects the carryback on one side of the belt and prevents it from entering between the return pulley and the belt. This reduces the risk of damage, i.e. holes developing in the conveyor belt, and wandering belts or mistracking.

The brackets for the plough are stable, easy to fasten and adjustable in height.

### CONDITIONS FOR THE DIAGONAL RETURN SCRAPER

- The conveyor belt must be free of damage.
- Max. belt speed: 2.8 m/s
- Max. temperature: + 50°C in wet environments / + 85°C in dry environments

#### CAUTION!

Always turn off the conveyor belt before maintaining, adjusting or installing the plough. Make sure that the belt cannot start while the work is in progress.

### WARRANTY

*The product is covered under 24months warranty from time of purchase. For questions or claims, please contact our customer service. Damage to the belt cleaner caused by incorrect handling or incorrect installation will not be considered subject to guarantee. Vendig will not be considered responsible for consequences or damage on other equipment or for injury due to incorrect handling or incorrect assembly. Warranty of Vendigs products is limited to manufacturing defects.*

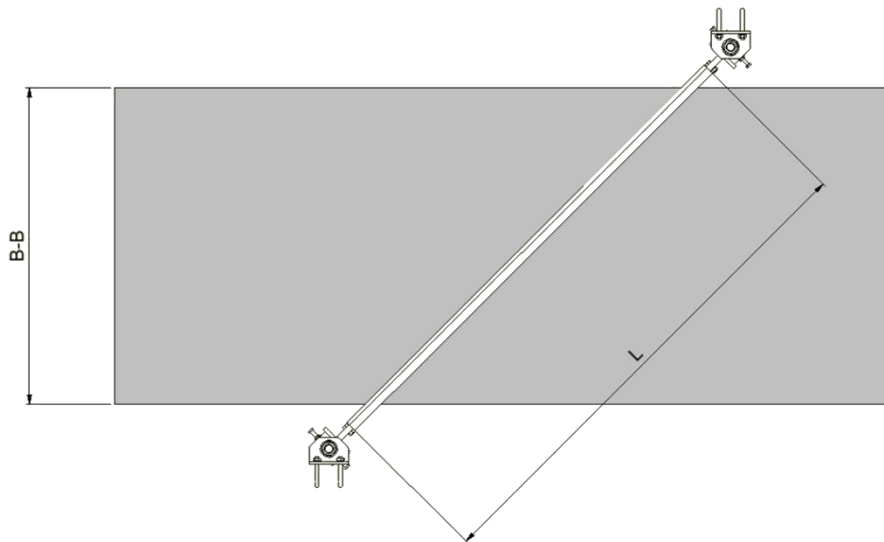

Picture 2

## ASSEMBLING

Turn off the belt conveyor. Place the diagonal return scraper on the upside of the returning belt .

- Install the scraper board (1) diagonally in the conveyor frame, threading the flat iron (3) through the scraper board and the holders PL1 (4). The holders are adjustable in height to adjust the pressure on the belt.
- Center the plough on the belt. Lock the scraper board (1) sidewise with the two set screws (2). Shorten the flat iron (3) if needed.
- Adjust the height of the scraper in order to minimize vibrations and noise when operating.

## MAINTENANCE

Inspect and clean the belt cleaner regularly, as a suggestion once a month. When 35 mm of the scrape strip (2) remains they should be exchanged.

## REPLACING THE SCRAPER STRIPS

Change the scraper strip (1) by removing the screws that hold it to the flat iron (2). Assemble new list on the flat iron.

